ND1208:2007/03

TSG/SER/008

MOBILE NUMBER PORTABILITY

© 2007 Ofcom copyright
NOTICE OF COPYRIGHT AND LIABILITY

Copyright

All right, title and interest in this document are owned by Ofcom and/or the contributors to the document unless otherwise indicated (where copyright be owned or shared with a third party). Such title and interest is protected by United Kingdom copyright laws and international treaty provisions.

The contents of the document are believed to be accurate at the time of publishing, but no representation or warranty is given as to their accuracy, completeness or correctness. You may freely download, copy, store or distribute this document provided it is not modified in any way and it includes this copyright and liability statement.

You may not modify the contents of this document. You may produce a derived copyright work based on this document provided that you clearly indicate that it was created by yourself and that it was derived from this document and provided further that you ensure that any risk of confusion with this document is avoided.

Liability

Whilst every care has been taken in the preparation and publication of this document, NICC, nor any committee acting on behalf of NICC, nor any member of any of those committees, nor the companies they represent, nor any person contributing to the contents of this document (together the "Generators") accepts liability for any loss, which may arise from reliance on the information contained in this document or any errors or omissions, typographical or otherwise in the contents.

Nothing in this document constitutes advice. Nor does the transmission, downloading or sending of this document create any contractual relationship. In particular no licence is granted under any intellectual property right (including trade and service mark rights) save for the above licence to copy, store and distribute this document and to produce derived copyright works.

The liability and responsibility for implementations based on this document rests with the implementer, and not with any of the Generators. If you implement any of the contents of this document, you agree to indemnify and hold harmless the Generators in any jurisdiction against any claims and legal proceedings alleging that the use of the contents by you or on your behalf infringes any legal right of any of the Generators or any third party.

None of the Generators accepts any liability whatsoever for any direct, indirect or consequential loss or damage arising in any way from any use of or reliance on the contents of this document for any purpose.

If you have any comments concerning the accuracy of the contents of this document, please write to:

The Technical Secretary,
Network Interoperability Consultative Committee,
Ofcom,
2a Southwark Bridge Road,
London SE1 9HA.

0.1 Contents

0	PREFACE	1
0.1	Title	1
0.2	Normative information	Error! Bookmark not defined.
0.3	Contents	3
0.4	History	4
0.5	Issue control	4
0.6	References	4
0.7	Glossary of terms	4
0.7.1	Definitions	4
0.7.2	Abbreviations	5
0.8	Scope.....	7
1	SERVICE DESCRIPTION - MOBILE NUMBER PORTABILITY	8
2	MNP SOLUTION - SIGNALLING RELAY FUNCTION	9
2.1	Background - mobile terminated calls	9
2.2	Signalling relay principle	9
2.3	Direct routeing override principle.....	11
2.4	Direct routeing override - recipient initiated	12
2.5	Direct routeing override - donor initiated	14
3	MNP INTERFACE REQUIREMENTS	16
3.1	Network interfaces	16
3.2	Signalling interfaces	16
3.2.1	Signalling operations affected by MNP.....	16
3.2.2	MTP addressing.....	17
3.2.3	SCCP addressing	17
3.2.4	SCCP number plan for signal relaying	17
3.2.5	IRN number plan for direct routeing override	18
3.3	Requirements on qualifying networks	18
3.3.1	Originating network requirements.....	18
3.3.2	Donor network requirements	19
3.3.3	Native Number Network requirements	19
3.3.4	Recipient network requirements	19
3.3.5	Transit network requirements	19
3.4	Requirements on SRF on receiving SRI from GMSC.....	19
4	CALL FLOWS	21
4.1	Voice call : basic signalling relay operation.....	21
4.2	Direct routeing override - recipient initiated	22
4.3	Direct routeing override - donor initiated	22
4.4	Optimal routeing.....	23
4.5	Mobile Originated Direct Routeing Option	23
4.5.1	Mobile Originated Call (A) to a Ported number (B) – Recipient DROF	23
4.5.2	Mobile Originated Call (A) to a Ported number (B) – Donor DROF	24
4.5.3	Mobile Originated Call (A) to a Non-Ported number (B).....	24
4.6	SMS delivery	25
4.7	SMS message waiting.....	26
4.8	CCBS.....	26
4.9	Send IMSI.....	27
5	SERVICE INTERACTIONS	28
5.1	Line identity presentation services	28
5.2	Emergency calls	28
5.3	CAMEL	28
5.4	Echo cancellers	28
6	CALL TRAP	29

7 ERROR HANDLING30
7.1 MTP/SCCP/TC errors30
7.2 Unsuccessful call completion or application errors30

APPENDIX A. ADDRESSING EXAMPLE FOR BASIC RELAY OPERATION.....30

APPENDIX B. ADDRESSING EXAMPLE FOR DIRECT ROUTEING OVERRIDE OPERATION – RECIPIENT INITIATED 31

0.2 History

Revision	Date of Issue	Updated By	Description
Issue 1	March 2000	Adrian Dodd Mike Eales Nick Sampson Simon Sporton	Editorial changes to conform with BSI format
Issue 2 Draft A	February 2005	Scott Bailey (3)	Editorial changes, Addition of new PLMN IRNs, Addition of Direct routeing method options
Issue 2 Draft B	February 2005	Scott Bailey (3)	Editorial changes, modification of figures 11, 12, & 13 to use 'gateway' rather than GMSC, and use STP rather than MSC.
Issue 2 Draft C	April 2005	Scott Bailey (3)	Addition of changes to 3.3, specifically new 3.3.3. Addition of new section 3.4. Modified 4.5 to allow IRN's to be used as well as MSISDNs for SRI enquires to donor operators
Issue 2 Draft D	May 2005	Scott Bailey (3)	Final draft – modified 3.4 table
Issue 2	June 2005	Scott Bailey (3)	Issued version for approval with editorial updates
Issue 3	February 2007	Petek Ergul (3)	Editorial changes for the new MRC ranges allocated by Ofcom for the new mobile voice providers.

0.3 Issue control

PAGE **ISSUE** **DATE**
All Issue 3 February 2007

0.4 References

- [1] MNPTG CP(97)022 MNPTG Interim Report Issue 1, MNPTG.
[2] ND1107:2001/10 PNO ISC/INFO/007 - UK Interconnect Use of SCCP
[3] The National Telephony Numbering Scheme (<http://www.ofcom.org.uk/telecoms/ioi/numbers/>)

0.5 Glossary of terms

0.5.1 Definitions

Direct Routeing Override	The prevention of routeing ported calls directly to the final destination from a gateway in the donor network without passing through the Recipient network
Donor network	The holder of the NNG range to which a ported directory number belongs.
Global Title	A form of SCCP addressing.
Intermediate Routeing Number	A number used to force a ported call into the recipient network for call processing treatment. This number is conveyed in the MSRN field within the MAP layer.
MNP Implementation	Method adopted by an operator to support an MNP solution.

MNP Solution	Standard method by which the UK industry manages and operates services for mobile subscriptions with ported numbers.
Native number	A number inside the NNG range allocated to the operator from Ofcom
Originating network	The network originating a call or service request.
Ported Call	A call to a ported number.
Porting data	The data in the donor network responsible for routeing signals to the appropriate recipient network.
Ported Number	The directory number originally allocated by the donor network to the ported subscriber.
Porting process	The process of moving a number from the donor network/SP to the recipient network/SP.
Qualifying Network	A network that has requested portability from another network and is able to provide portability to that network.
Recipient network	The network receiving a new subscription with a ported number.
Service Provider	The entity contracted to provide retail air time to the subscriber.
Subscriber	User of a mobile phone responsible for payment of the subscription account.

0.5.2 Abbreviations

A Party	Calling party
B Party	Called party
CAMEL	Customised Applications for Mobile network Enhanced Logic
CCBS	Completion of Calls to Busy Subscribers
CdPA	SCCP Called Party Address
CgPA	SCCP Calling Party Address
CND	Calling Number Display
CUG	Closed User Group
DNW	Donor Network
RNW	Recipient Network
DECT	Digital Enhanced Cordless Telecommunications
DROF	Direct Routeing Override Function
FTN	Forwarded To Number
GMSC	Gateway MSC
GNP	Geographic Number Portability
HLR	Home Location Register
IMSI	International Mobile Subscriber Identity
IRN	Intermediate Routeing Number
MAP	Mobile Application Part
MNP	Mobile Number Portability
MRC	MNP Rerouteing Code
MSIN	Mobile Subscriber Identity Number
MSISDN	Mobile Subscriber ISDN Number
MSRN	Mobile Subscriber Roaming Number
MVNO	Mobile Virtual Network Provider
NICC	Network Interoperability Consultative Committee
NGNP	Non-Geographic Number Portability
NNG	National Number Group
ONW	Originating Network
OR	Optimal Routeing
POI	Point Of Interconnect
PRN	Provide Roaming Number
SCCP	Signalling Connection Control Part
SIM	Subscriber Identity Module
SMS	Short Message Service

SRF	Signalling Relay Function
SRI	MAP Send Routeing Information
SRI-SMMAP	Send Routeing Information for Short Message
TAP	Transfer Accounting Procedure
TSG	Technical Steering Group
UMTS	Universal Mobile Telecommunications System
USSD	Unstructured Supplementary Service Data
VMSC	Visited MSC
WiFi	Wireless Fidelity

0.6 Scope

A feasibility study on Mobile Number Portability (MNP) [1] produced by the UK telecommunications industry concluded that of the proposed technical solutions the method based on Signalling Relay Functionality (SRF) was preferred for the UK. This is a non-circuit related signalling technique and is a different approach to that taken for fixed number portability.

The purpose of this document is to describe the operation of UK MNP based on a SRF implementation.

This service description places requirements on the interconnect for participating MNP networks. The service description does not place any requirements on the implementation adopted within a network except to the extent that the implementation supports the requirements of the interconnect.

The MNP service covers numbers allocated to GSM 900, GSM 1800 and, 3G UMTS network operators as well as the numbers allocated to MVNOs, WiFi providers and DECT guard-band communications providers.

The MNP service description in this document is only applicable to GSM and UMTS networks, not WiFi networks.

Items not covered by this service description are:

- Billing and administration system requirements
- Porting process requirements
- CDR transfer process requirements
- Roaming information transfer requirements

This service description deals only with mobile terminating transactions. This is because mobile originated transactions initiated by the ported subscriber do not involve the ported number.

This service description does not deal with transactions based on International Mobile Subscriber Identities (IMSI) since IMSIs are not ported and once allocated by the recipient network operate as normal. An example IMSI based transaction is Location Updating.

This service description describes a model for the implementation of MNP using generic terms to denote functionality in qualifying networks in order to ease understanding.

The implementation of functional entities described in section 2 of this document is a matter for the qualifying networks and is not mandated.

However the MNP Interface specification described in section 3 is mandatory for MNP. Sections 0, 1, 2, 4, 5, 6, and 7 are included for information.

1 SERVICE DESCRIPTION - MOBILE NUMBER PORTABILITY

MNP is the ability for a mobile subscriber to change network operator whilst retaining their original directory number for each service used in the new network. The move may, or may not, include a change in service provider.

MNP is not service portability, ie if a service supported in the old network is not available on the new network then number porting mechanisms will not provide that service for the porting subscriber.

Number porting involving GSM or UMTS subscriptions does not include porting the IMSI. When porting to a GSM or UMTS subscription a new SIM and IMSI are provided by the recipient network.

2 MNP SOLUTION - SIGNALLING RELAY FUNCTION

This section uses generic terms to denote functionality in qualifying networks. The implementation of functional entities described in this section is a matter for the qualifying networks in order to meet the MNP Interface requirements in section 4.

2.1 Background - mobile terminated calls

In mobile networks, calls cannot be delivered to mobile subscribers simply by means of analysing the digits dialled because the mobile can be anywhere in the mobile network or even roaming abroad. To deliver a call a Routeing Enquiry is made to a Home Location Register (HLR) to determine where the called subscriber is located and to obtain a routeing number, see Figure 2.1. The Routeing Enquiry is a C7 based signal. The routeing number is temporarily allocated to the called subscriber and relates to the visited switch.

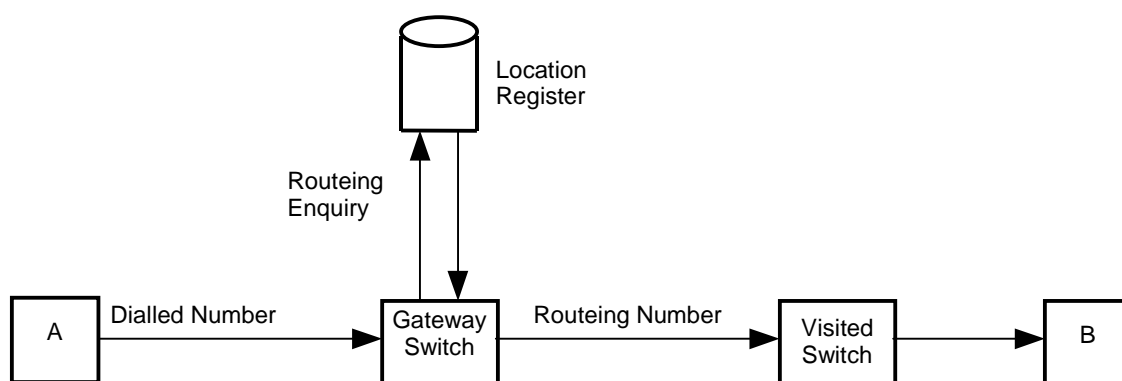

Figure 2.1 - Generic Mobile Terminated Call.

2.2 Signalling relay principle

The signalling relay principle takes advantage of the routeing enquiry signal to provide number portability. The principle is that the donor network (or mobile originating network) sends the routeing enquiry signal or other signal addressed to a ported number to the appropriate recipient network for treatment, see Figures 2.2a, 2.2b and 2.2c. In this way the recipient network can provide the routeing number or other result to complete the routeing of the call or transaction.

The figures below are largely logical diagrams only showing the source and the destination of signals not the physical path. Detailed call flows are given in Section 4.

Service request indicates a circuit related call or a signal entering the donor network addressed to the ported number.

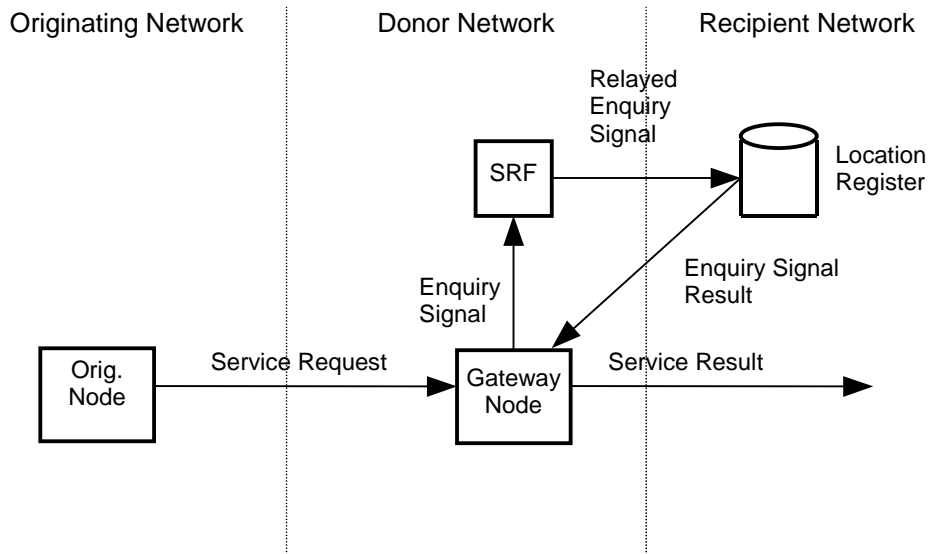

Figure 2.2a - Signalling Relay Operation - Circuit Related Call routing enquiry

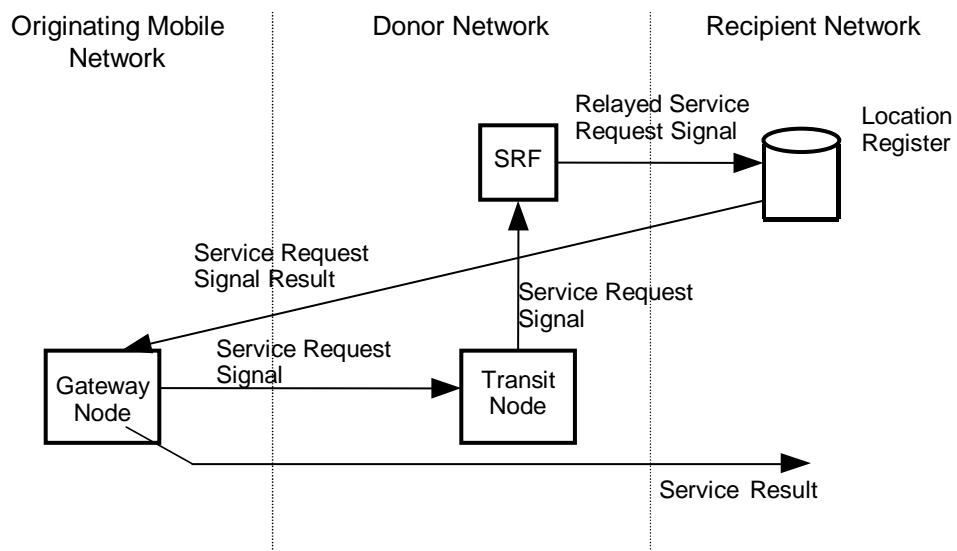

Figure 2.2b - Signalling Relay Operation – Mobile Originated Circuit Related 'Direct Routing' enquiry

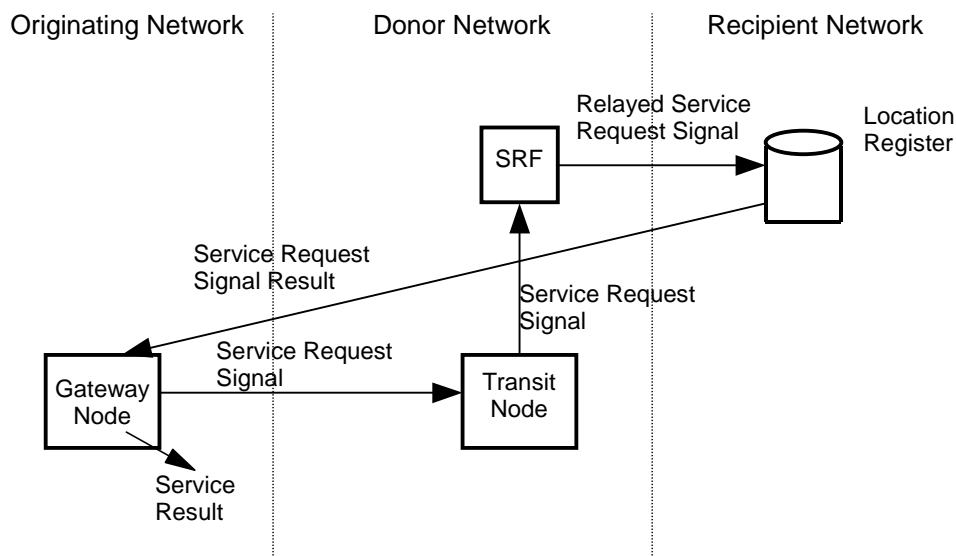

Figure 2.2c - Signalling Relay Operation - Signals other than circuit related call routing enquiries

A Signalling Relay Function (SRF) is required in the donor network to provide this functionality. The SRF shall include the functionality to:

1. Determine for which directory numbers relaying is applicable
2. Determine to which network relaying should be directed
3. Modify SCCP addressing to relay signals to the recipient network

2.3 Direct routing override principle

The effect of the SRF is that the recipient network controls the routing of the call from a gateway in the donor network. The result is that there is a direct routing between the donor's gateway and the ultimate destination of the call.

Calls to ported mobiles operating in the recipient network are therefore routed through the donor network to the recipient network, as shown in Figure 2.2a. However, if the called party is roaming in another network, or has set an unconditional divert to an off-net number, the call will be routed direct from the donor network to this destination and will not enter the recipient network, see Figure 2.3.

The figure below is a logical diagram only showing the source and the destination of signals not the physical path.

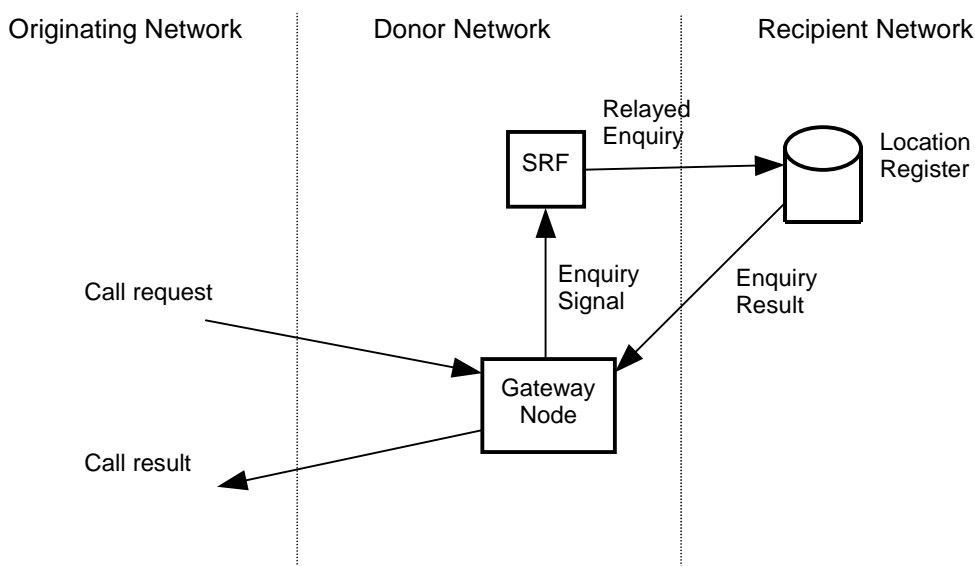

Figure 2.3 - Roaming/CFU Call Scenario

For the scenarios shown in Figure 2.3, several issues arise :

- the recipient network is unable to raise its own CDRs relating to the call
- the donor network will incur costs in delivering the call to a ported number
- recipient networks may offer proprietary services which rely on functionality in their own gateway, for example terminating IN services. Use of SRF may compromise this functionality
- the calling party may receive donor-network announcements and announcement charges when calling ported numbers

To address these issues, the Interconnect Policy Forum MNP Focus Group has stated that calls to ported numbers shall route through the recipient network. To achieve this a Direct Routing Override (DRO) function is defined, the purpose of which is to force calls to ported numbers into the recipient network. DRO can be initiated by the Recipient Network or the Donor Network.

2.4 Direct routing override - recipient initiated

Recipient initiated DRO is achieved by sending an Intermediate Routing Number (IRN) to the donors or originating mobile operators gateway node, see Figures 2.4a and 2.4b. The intermediate routing number contains a prefix which has the effect of routing the call into the recipient network. Once in the recipient network the call undergoes a second routing enquiry for the final stage of routing.

Recipient initiated DRO is only applicable to routing enquiries for circuit related calls. All other signals are relayed to the recipient location register function

Figure 2.4a below shows the action of the Recipient initiated DRO for routing enquiries for circuit related calls that have entered the Donor operator

Figure 2.4b below shows the action of the Recipient initiated DRO for routing enquiries for circuit related calls originating from a mobile operator following the "Direct Routing" principle.

Figure 2.4c below shows the action of the Recipient initiated DRO for the routing of signals other than routing enquiries for circuit related calls.

The figures below are logical diagrams only showing the source and the destination of signals not the physical path. The numbers on each signal indicate the sequence of signals.

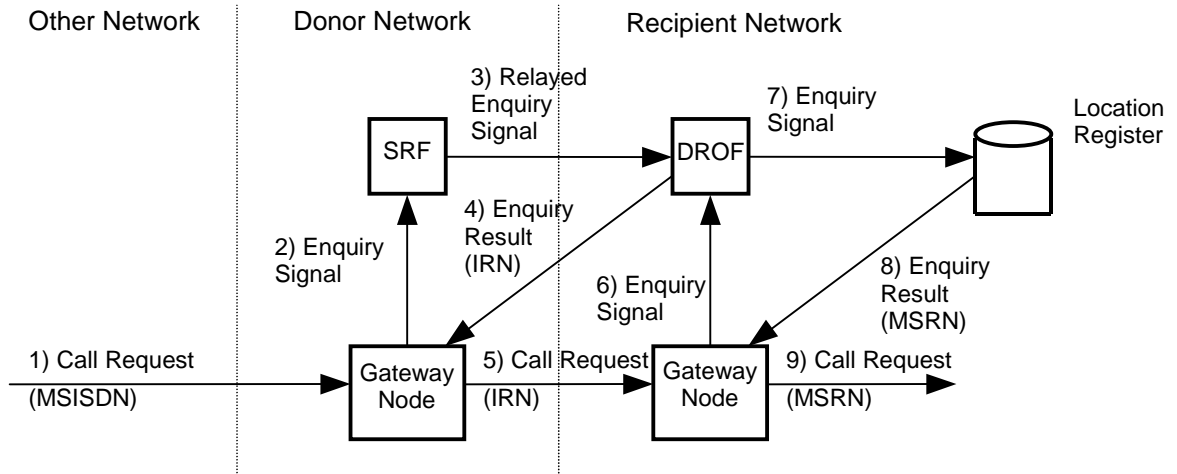

Figure 2.4a - Direct Routing Override - Recipient Initiated – Circuit Routing

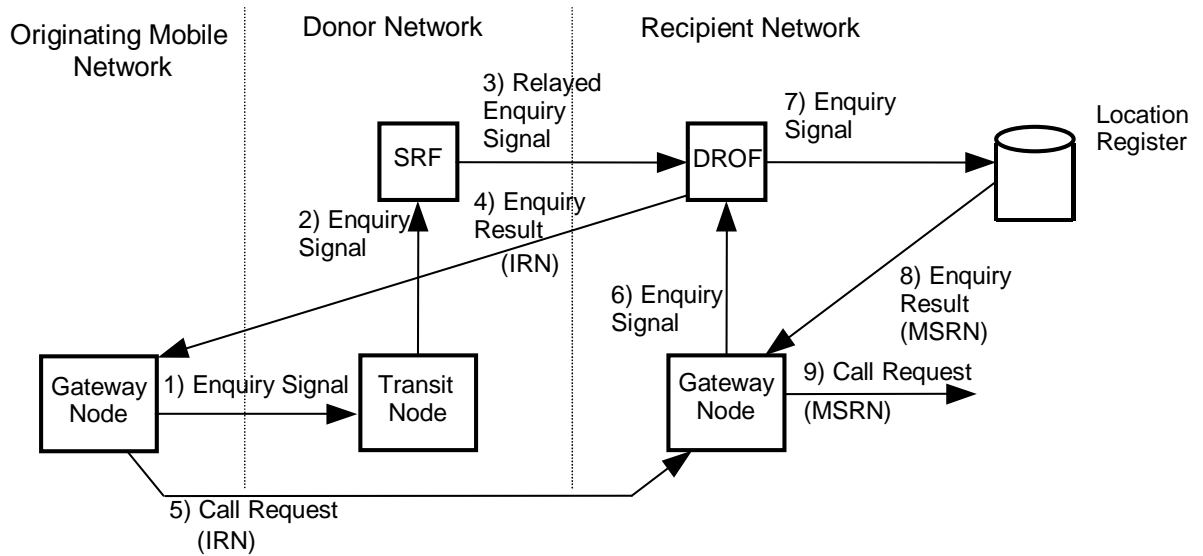

Figure 2.4b - Direct Routing Override - Recipient Initiated – Mobile Originated 'Direct Routing' option

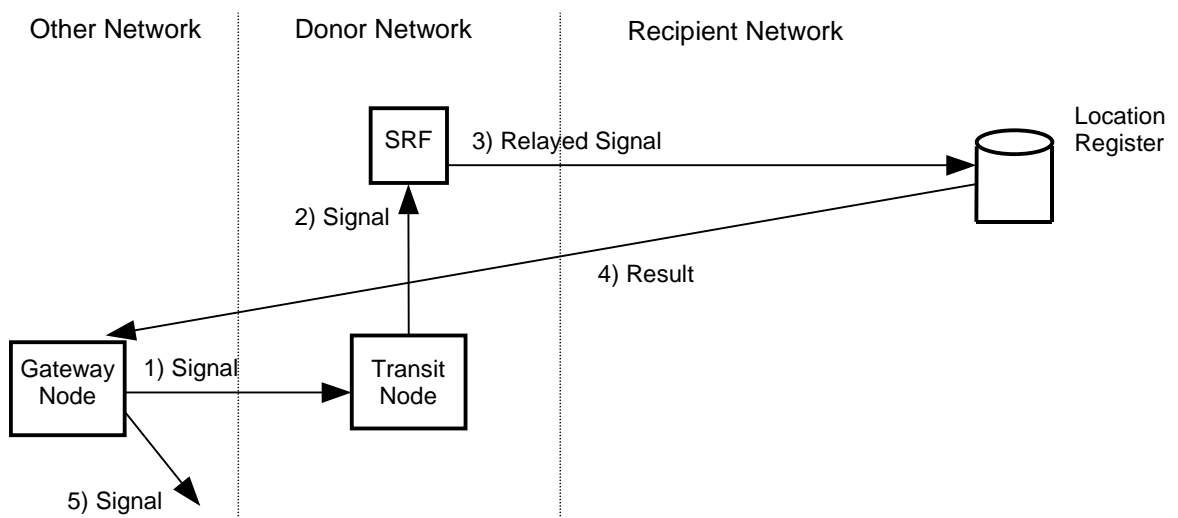

Figure 2.4c - Direct Routing Override - Recipient Initiated - Signals other than circuit related call routing enquiries

A DRO function (DROF) is required in the recipient network to invoke DRO at the appropriate times. The DROF contains:

1. proprietary criteria defined by the recipient network for invoking DRO
2. functionality to determine which signals are applicable for DRO
3. functionality to differentiate between the first and second routing enquiries

The method of routing enquiry differentiation is up to the recipient network, however it is recommended that the SCCP Called Party Address is used (in the first routing enquiry this will contain the MNP prefix).

If a signal meets the criteria for DRO and is a first enquiry the DROF should return an intermediate routing number, otherwise standard treatment of signals should be applied by the recipient network.

The standard GSM MSRN can be used by the Recipient DROF in place of an IRN number so long as the call will be routed into the recipient network as a result.

In the Mobile Originated 'Direct Routing' method (Figure 2.4b) the result of the enquiry signal will always be an IRN number. This applies even if the MSISDN in the enquiry signal belongs to the donor network (hence the number has not been ported out.) The IRN will be then used by the originating mobile network to route to the recipient network. It is worth noting that if the call passes through a transit operator, then the recipient network may not be able to determine if the call has actually passed through the donor network, or has been routed from the originating mobile network. This may cause some interconnect settlement issues.

2.5 Direct routing override - donor initiated

Donor initiated DRO is achieved by sending an intermediate routing number to the donor gateway node, as before, except in the donor initiated case the SRF generates the enquiry result rather than the recipient network, see Figure 2.5a. Once in the recipient network, the call enters the standard routing enquiry stage.

Donor initiated DRO is only applicable to routing enquiries for circuit related calls. All other signals are relayed to the recipient location register function.

Figure 2.5a below shows the action of the Donor initiated DRO for routing enquiries for circuit related calls that have entered the Donor operator.

Figure 2.5b below shows the action of the Donor initiated DRO for routing enquiries for circuit related calls from a mobile operator following the 'Direct Routing' principle.

Figure 2.5c below shows the action of the Donor initiated DRO for the routing of signals other than routing enquiries for circuit related calls.

The figures below are logical diagrams only showing the source and the destination of signals not the physical path. The numbers on each signal indicate the sequence of signals.

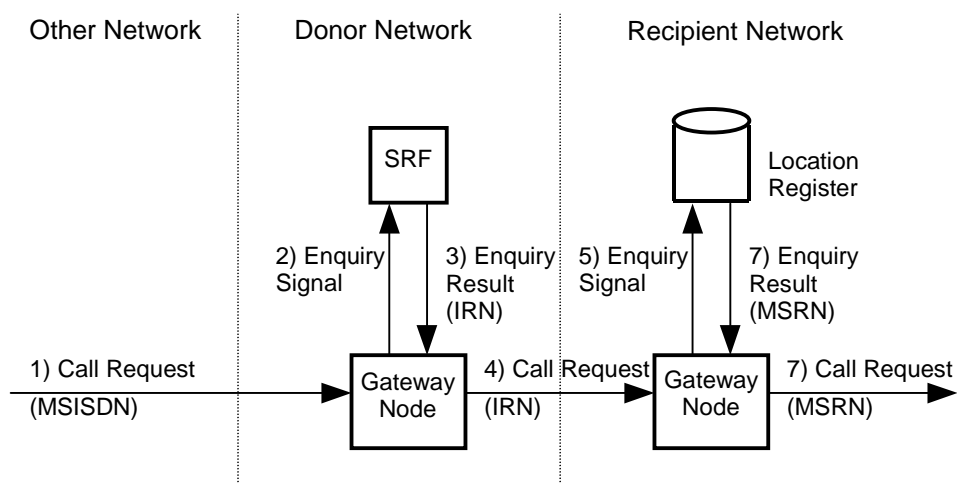

Figure 2.5a - Direct Routing Override - Donor Initiated - Circuit Related Call Routing enquiry

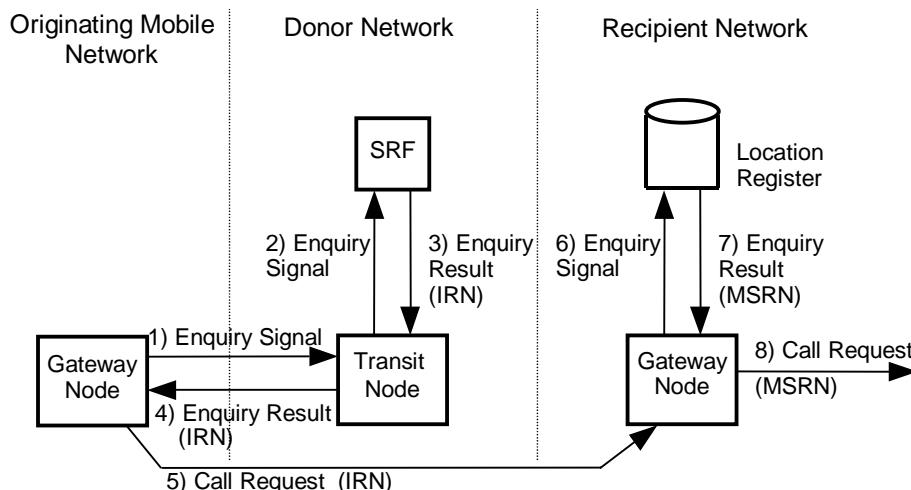

Figure 2.5b - Direct Routing Override - Donor Initiated - Mobile Originated 'Direct Routing' option

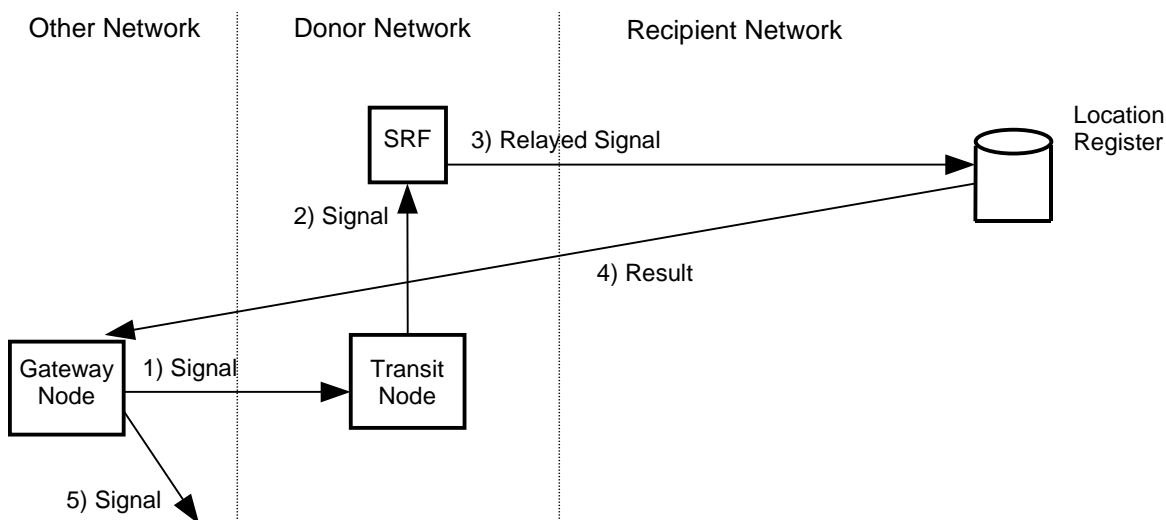

Figure 2.5c - Direct Routing Override - Donor Initiated - Signals other than circuit related routing enquiries

A DRO function (DROF) is required in the donor network to invoke DRO at the appropriate times. The DROF contains:

1. proprietary criteria defined by the donor network for invoking DRO
2. functionality to determine which signals are applicable for DRO
3. functionality to return an IRN for signals which are applicable for DRO
4. signalling relay functionality for signals which are not applicable for DROF.

In the same manner as recipient initiated DROF, in the Mobile Originated 'Direct Routing' method (Figure 2.5b) the result of the enquiry signal will always be an IRN number. This applies even if the MSISDN in the enquiry signal belongs to the donor network (hence the number has not been ported out.) The IRN will be then used by the originating mobile network to route to the recipient network. It is worth noting that if the call passes through a transit operator, then the recipient network may not be able to determine if the call has actually passed through the donor network, or has been routed from the originating mobile network. This may cause some interconnect settlement issues.

3 MNP INTERFACE REQUIREMENTS

This section defines the MNP interface between qualifying networks and is a mandatory requirement for MNP.

3.1 Network interfaces

A ported call uses a dialled directory number from the number range of a donor network but the call must be delivered to the recipient network of the called subscriber. To support this requirement an MNP interface is required between the donor and recipient network. The interface may be direct or indirect, therefore the mandatory requirements of the interface must be supported by donor, recipient and transit networks, see Figure 3.1.

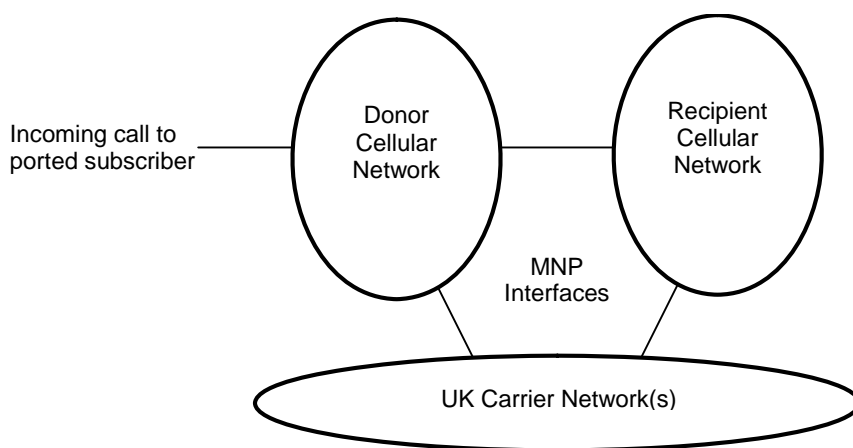

Figure 3.1 MNP Interfaces.

3.2 Signalling interfaces

3.2.1 Signalling operations affected by MNP

The signalling systems operating across the MNP interconnect shall be the C7 based Mobile Application Part and ISDN Supplementary Services ASEs as applicable. These application parts shall be supported by the C7 signalling layers, MTP, SCCP and TCAP.

The operations affected by MNP are those addressed at the SCCP layer on the MSISDN of a ported subscriber. The current standardised messages routed on MSISDN are shown in the table below:

Operation	Name	Protocol	Applicable for DRO
sendRouteingInformation	SRI	MAP	Yes
sendRouteingInformation (OR)	SRI(with OR parameters)	MAP	No (NOTE)
sendRouteingInfoForSM	SRI-SM	MAP	No
setMessageWaitingData	SMWD	MAP	No
reportSM-DeliveryStatus	Report SM Delivery Status	MAP	No
CcbsRequest	CCBS Request	CCBS ASE	No
CcbsSuspension	CCBS Suspension	CCBS ASE	No
CcbsResume	CCBS Resume	CCBS ASE	No
CcbsCancel	CCBS Cancel	CCBS ASE	No
sendImsi	Send IMSI	MAP	No
anyTimeInterrogation	Any Time Interrogation	MAP	No

Table 3.1 - Operations subject to the MNP SRF

NOTE: If optimal routing is not allowed, the Recipient network may either return an 'OR not allowed' error (in which case the call will be routed to the donor network) or (preferably) return an IRN in the MSRN field of the acknowledgement, thus causing the call to be routed directly to the recipient network. In order to allow OR the donor network should relay SRIs transparently to the recipient network.

Version differences of MAP operation shall be dealt with by MAP version negotiation mechanisms.

3.2.2 MTP addressing

Non circuit related messages routed from Donor to Recipient networks should be addressed to a node which will perform Global Title Translation to determine the final destination of the message. In this way Donor networks will not require knowledge of all Recipient network HLRs.

3.2.3 SCCP addressing

MAP operations are routed on Global Title in the SCCP layer. A re-routing code is required to relay the signal to the recipient network. This is inserted by the Donor network from the ported subscribers provisioned data. The SCCP Called Party Address is the modified field.

A standard signalling re-routing number plan is required for SCCP interconnect to allow signal relaying, see following section. Where interconnect is achieved through transit networks the transit network is required to support the signalling re-routing number plan. The addressing of SCCP messages between the donor and recipient is as follows (please refer to [2] for details of SCCP parameters):

Protocol Layer	Field	Number
MAP	MSISDN	7abc SN 447abc SN
SCCP	CdPA Address Indicator	RI=GT, GTI=0100, SSNI =1, PCI=0
SCCP	CdPA	SSN=6 (HLR) or 11 (ISDN ASE) TT=0, NPI=E164, NAI=International, GT=447XYZ abc SN
SCCP	CgPA	Originating Node Address

Table 3.2.3 - MNP SCCP Addressing

Responses to the relayed operations are addressed in the standard way using the received calling party address.

3.2.4 SCCP number plan for signal relaying

The SCCP MNP re-routing number is defined as follows:

CC	MRC	abc	SN
----	-----	-----	----

Digit	Name	Value
CC	Country Code	44
MRC (NOTE 1)	MNP Re-routing Code	7XYZ
Abc (NOTE 2)	NNG	ported number nng
SN	Subscriber Number	ported number

Table 3.2.4 - MNP SCCP Called Party Address format

NOTE 1: The value of 'XYZ' is administered by Ofcom. For individual MRCs allocated to each mobile network operators, please refer to The National Telephony Numbering Scheme (<http://www.ofcom.org.uk/telecoms/ioi/numbers/>).

NOTE 2: The NNG will not need to have the leading (mobile) service digit 7.

The donor network shall ensure that the above addressing format is provided at interconnect interfaces.

3.2.5 IRN number plan for direct routing override

The IRN carried in the MSRN field of the appropriate MAP signals shall take following standard format:

CC	MRC	abc	SN
----	-----	-----	----

IRN = 447XYZ abc SN (NAI=International, NPI=E164)

Digit	Name	Value
CC	Country Code	44
MRC (NOTE 1)	MNP Re-routing Code	7XYZ
Abc (NOTE 2)	NNG	ported nng
SN (NOTE 2)	Subscriber Number	ported number

Table 3.2.5 - International IRN format

NOTE 1: The value of 'XYZ' is administered by Ofcom. For individual MRCs allocated to each mobile network operators, please refer to The National Telephony Numbering Scheme (<http://www.ofcom.org.uk/telecoms/loi/numbers/>).

NOTE 2: The abc and/or the SN digits may be manipulated by the recipient in order to include additional information in the IRN number. The MRC ensures routing to the correct network. The NNG will not need to have the leading (mobile) service digit 7.

The national format of the IRN carried in the MSRN field of appropriate MAP signals is included below for completeness.

	MRC	abc	SN
--	-----	-----	----

IRN = 7XYZ abc SN (NAI=National, NPI=E164)

Digit	Name	Value
MRC (NOTE 1)	MNP Re-routing Code	7XYZ
abc (NOTE 2)	NNG	ported NNG
SN (NOTE 2)	Subscriber Number	ported number

Table 3.2.6 - National IRN format

NOTE 1: The value of 'XYZ' is administered by Ofcom. For individual MRCs allocated to each mobile network operators, please refer to The National Telephony Numbering Scheme (<http://www.ofcom.org.uk/telecoms/loi/numbers/>).

NOTE 2: The abc and/or the SN digits may be manipulated by the recipient in order to include additional information in the IRN number. The MRC ensures routing to the correct network. The NNG will not need to have the leading (mobile) service digit 7.

The IRN used in interconnect circuit-related signalling shall contain the MNP re-routing code, the NNG and the subscriber number as defined above. The nature of address of the IRN shall be any that is supported by the interconnect signalling, for example "07XYZ abc 123456."

3.3 Requirements on qualifying networks

3.3.1 Originating network requirements

If the Originating network is not a mobile operator following the optional direct routing method, there are no requirements.

Originating mobile networks following the optional 'Direct Routing' method, following an SRI enquiry to the Donor network, shall route circuit switched calls directly from the Originating mobile network towards the Recipient network using the MNP IRN numbering plan specified in section 3.2.5 and relay other non circuit related signals addressed to a ported number as illustrated in section 3.2.1 towards the Recipient network

using the MNP SCCP numbering plan specified in sections 3.2.3 and 3.2.4. By implementing this method use of Call Trap (see Section 6) will most likely be implemented first.

3.3.2 Donor network requirements

Qualifying Donor networks shall either:

Relay all non circuit related routing enquiry signals and other signals addressed to a ported number as illustrated in section 3.2.1 towards the Recipient network using the MNP SCCP numbering plan specified in sections 3.2.3 and 3.2.4.

or

Route circuit switched calls arriving in the donor network towards the Recipient network using the MNP IRN numbering plan specified in section 3.2.5 and relay other non circuit related signals addressed to a ported number as illustrated in section 3.2.1 towards the Recipient network using the MNP SCCP numbering plan specified in sections 3.2.3 and 3.2.4.

Qualifying Donor networks shall support routing of IRN numbers towards the appropriate Recipient network.

3.3.3 Native Number Network requirements

Applying to circuit related calls, if the direct routing option is followed for the non circuit related routing enquiry signals addressed to native numbers, the number range owning network shall return an IRN number using the MNP IRN numbering plan specified in section 3.2.5. to the interrogating node in the originating network.

3.3.4 Recipient network requirements

In response to a non circuit related routing enquiry signal relayed by the Donor network, qualifying Recipient networks shall ensure that a circuit switched call to a ported number always enters the Recipient network by returning either a standard MSRN number belonging to the recipient network or an IRN number using the MNP IRN numbering plan specified in section 3.2.5.

In response to other non circuit related signals relayed by the Donor network, qualifying Recipient networks shall apply normal handling as illustrated in section 3.2.1

Qualifying Recipient networks shall support routing of IRN numbers sent from Donor networks.

3.3.5 Transit network requirements

Networks providing SCCP transit functionality between donor and recipient networks are required to support the MNP re-routing numbering plan defined in section 3.2.3 and 3.2.4

Networks providing call routing between qualifying networks shall support routing of IRN numbers defined in section 3.2.5.

3.4 Requirements on SRF on receiving SRI from GMSC

This implies the requirements stated in 3.3. The table below shows the SRF actions on receiving SRI from GMSC (or GMSC type interrogating node).

	SRI from own GMSC	SRI from other UK GMSC
Non-Ported MSISDN	Route SRI to HLR	<i>Return SRF owners IRN in MSRN of SRI response (NOTE)</i>
Ported In MSISDN	Route SRI to HLR	Return SRF owners IRN in MSRN of SRI response
Ported Out MSISDN	Return IRN of recipient	<i>Return IRN of recipient</i>

	network or forward SRI to recipient HLR	<i>network or forward SRI to recipient HLR (NOTE)</i>
--	---	---

NOTE - Only expected if direct routing option used between interrogating mobile operator and SRF owner.

4 CALL FLOWS

The diagrams in the following sections describe only the relevant nodes, Messages and Parameters at the various protocol layers for each scenario.

4.1 Voice call: basic signalling relay operation

The following call flow will only occur in practice if the Recipient-initiated DRO function uses an MSRN number in place of the IRN number. This is permitted so long as the call will route into the recipient network.

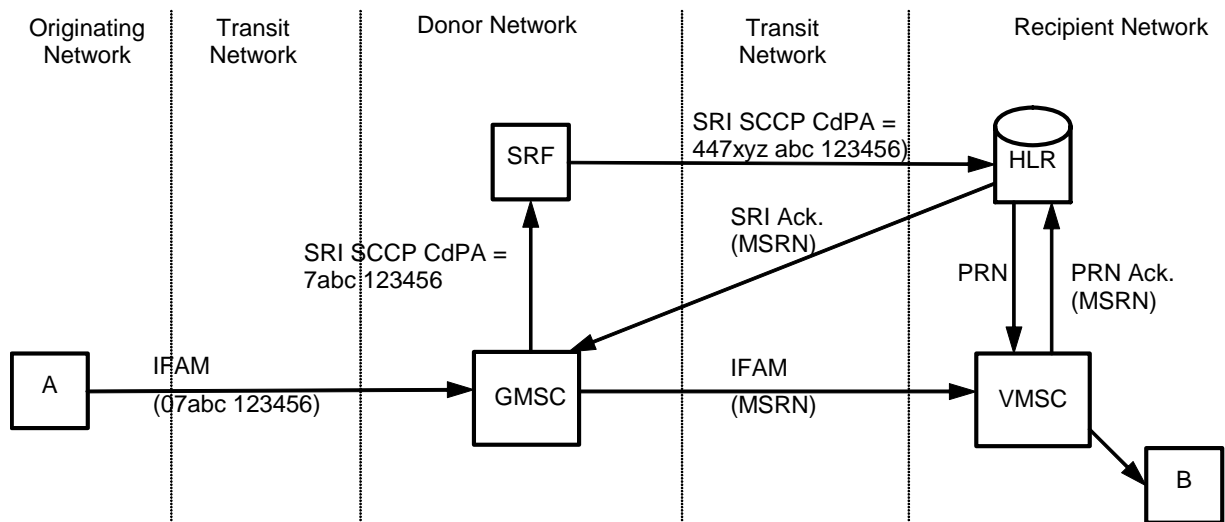

Figure 4.1a - Signalling Relay Operation - Ported

The following call flow is included for information to illustrate the handling of a non ported number with the SRF in operation in the donor network.

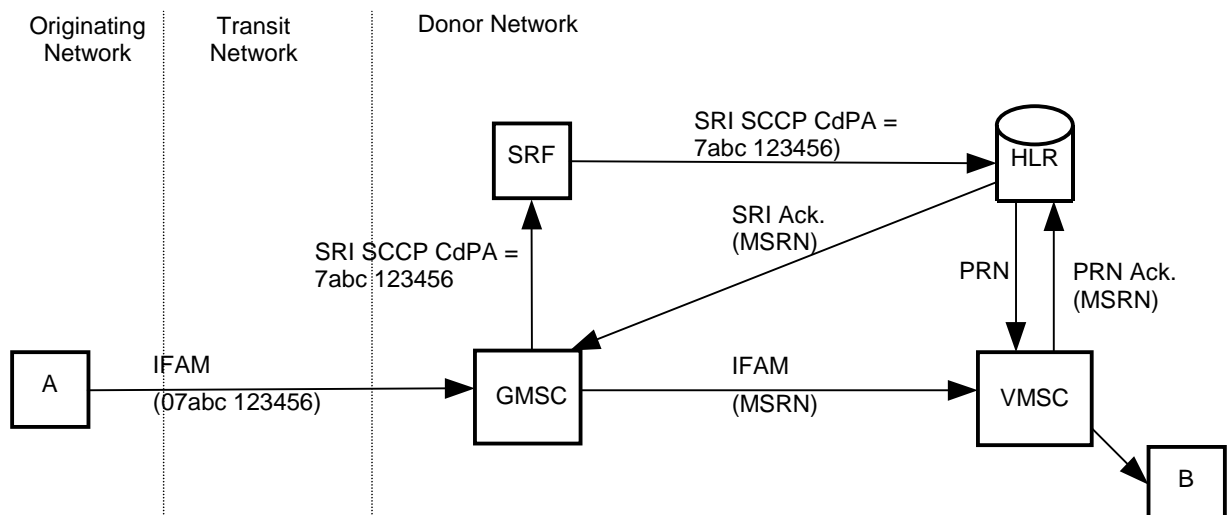

Figure 4.1b - Signalling Relay Operation - Non Ported Number

4.2 Direct routing override - recipient initiated

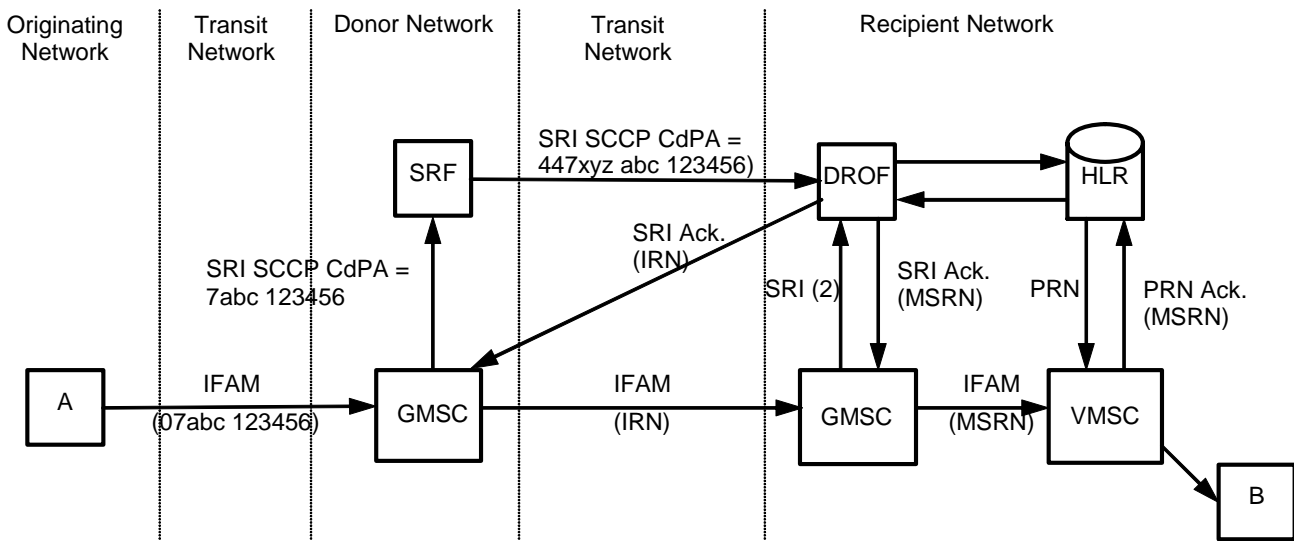

Figure 4.2 - Direct Routing Override Operation - Recipient Initiated

4.3 Direct routing override - donor initiated

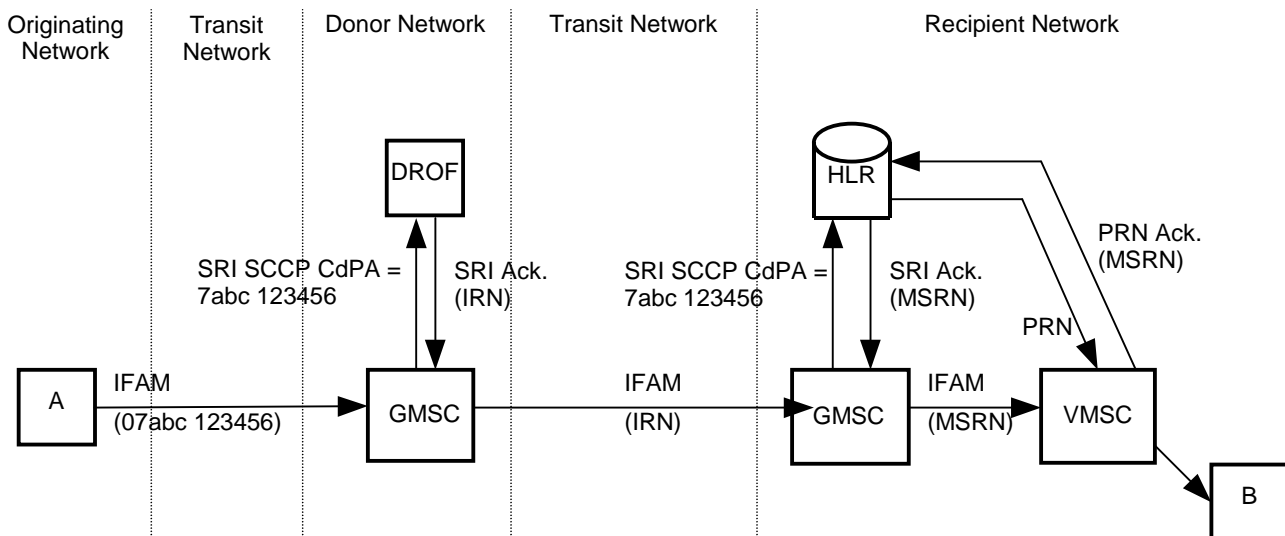

Figure 4.3 - Direct Routing Override Operation - Donor

4.4 Optimal routing

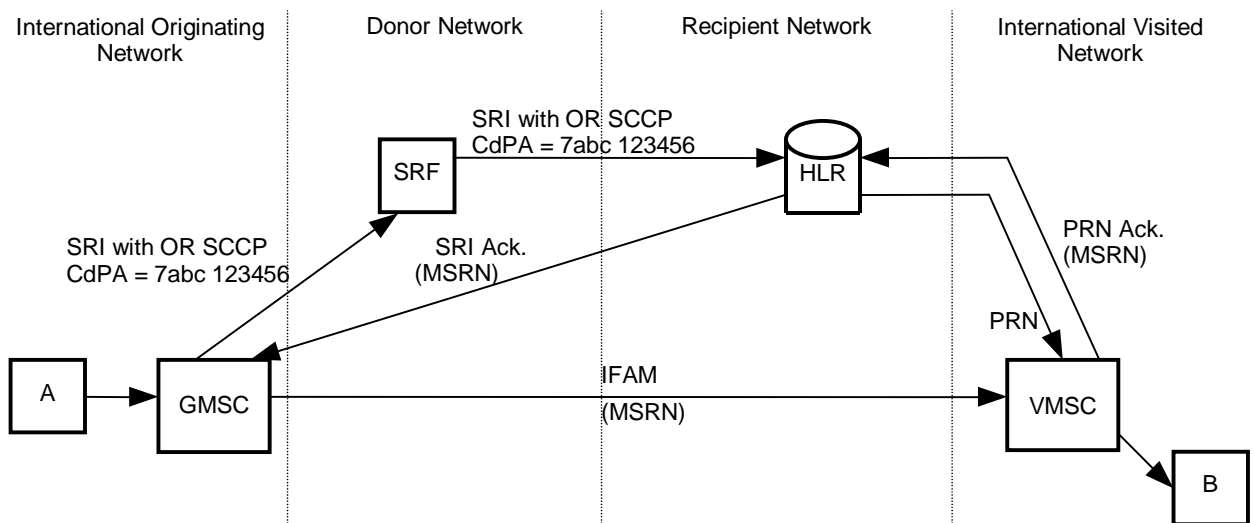

Figure 4.4 – Signalling Relay Interaction with Optimal Routing

4.5 Mobile Originated Direct Routing Option

The opportunity to deliver circuit related calls directly from the originating mobile operator to the recipient mobile operator (that may be the same network) whether the MSISDN dialled is ported or not is possible. This means that the call would not need to pass through the Donor network, but only the signalling enquiries. This All Mobile Call Query method is optional, and is presented logically for R-DROF and D-DROF in figures 2.4b and 2.5b.

This section will illustrate some basic call options using the 'Direct Routing' option for R-DROF and D-DROF only. Figures 4.5.1 and 4.5.2 illustrate this below.

4.5.1 Mobile Originated Call (A) to a Ported number (B) – Recipient DROF

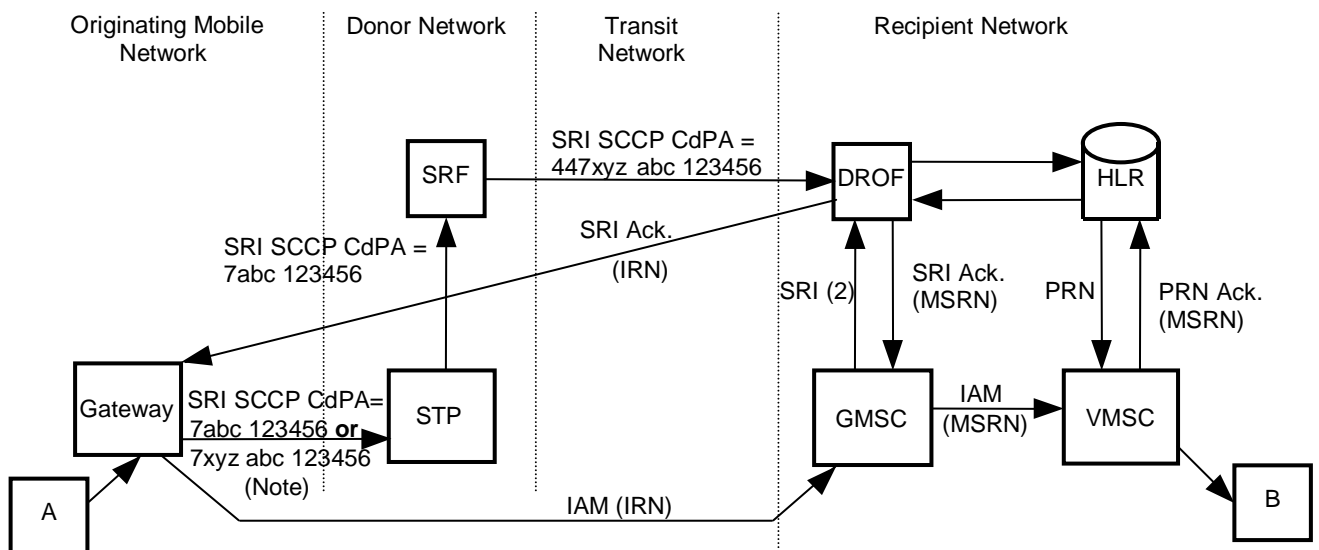

Note: The SRI from the Originating Mobile Network to the STP of the Donor can have SCCP CdPA of either MSISDN (7abc 123456) or IRN in the format for the Donor (7xyz abc 123456). This is to be bilaterally agreed.

Figure 4.5.1 – Mobile Originated Direct Routing – R-DROF

4.5.2 Mobile Originated Call (A) to a Ported number (B) – Donor DROF

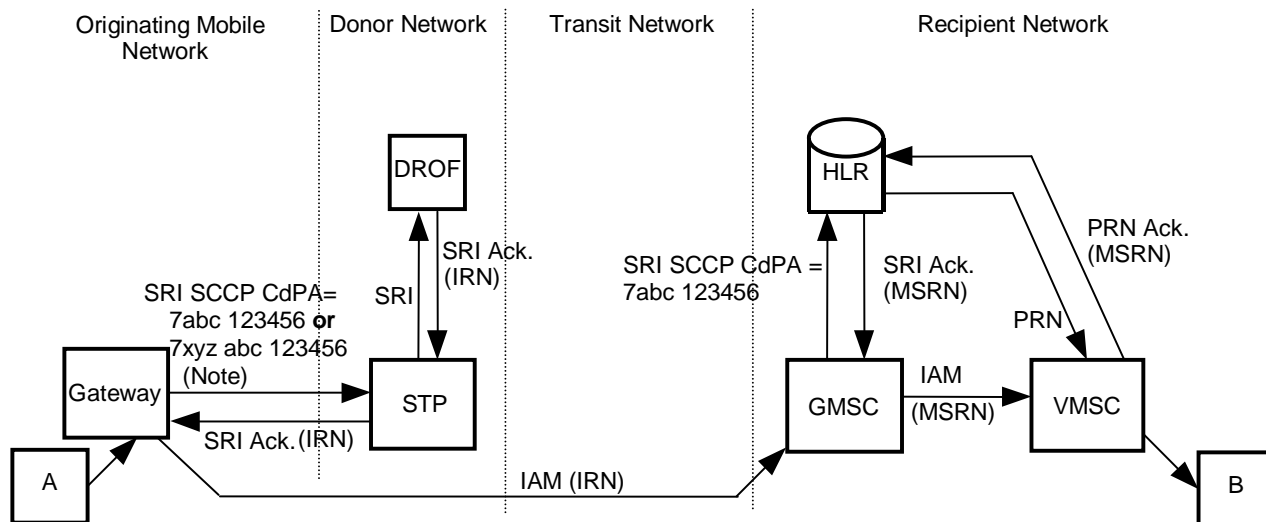

Note: The SRI from the Originating Mobile Network to the STP of the Donor can have SCCP CdPA of either MSISDN (7abc 123456) or IRN in the format for the Donor (7xyz abc 123456). This is to be bilaterally agreed.

Figure 4.5.2 – Mobile Originated Direct Routing – D-DROF

4.5.3 Mobile Originated Call (A) to a Non-Ported number (B)

This scenario shows that although the MSISDN dialled is not ported, the IRN is used for the network that 'B' belongs to (Native Number). The call therefore always Gateways in the home network of subscriber 'B'.

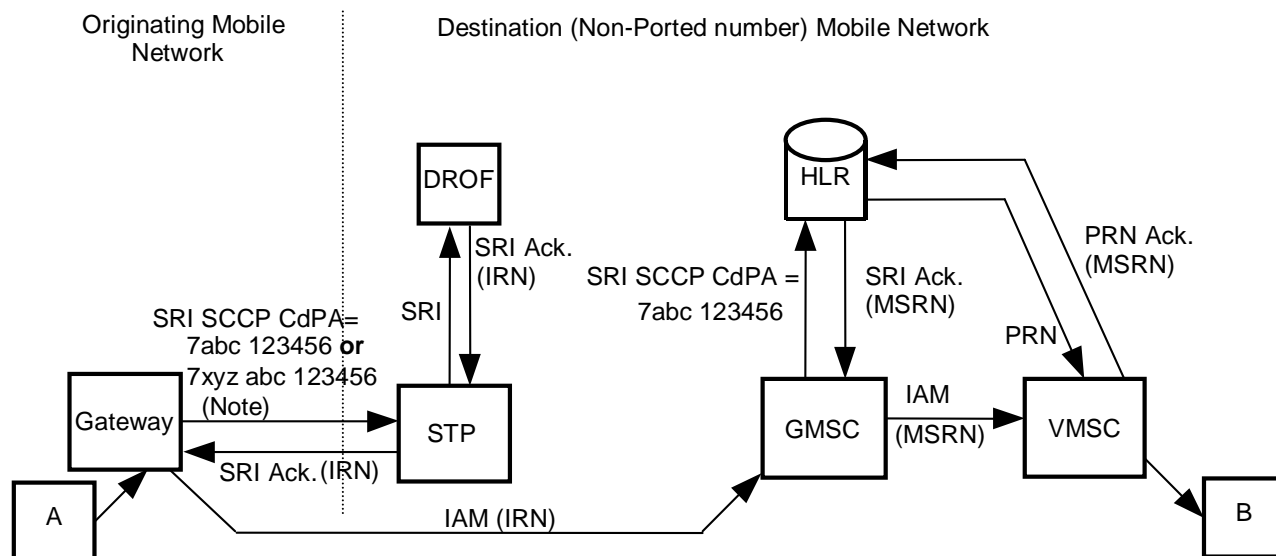

Note: The SRI from the Originating Mobile Network to the STP of the Destination network can have SCCP CdPA of either MSISDN (7abc 123456) or IRN in the format for the Destination (7xyz abc 123456). This is to be bilaterally agreed.

Figure 4.5.3 – Mobile Originated Direct Routing to a Non-Ported MSISDN

If an MSISDN is used in the SRI SCCP CdPA from the Originating Mobile Network, in order for the DROF function to avoid routing the SRI query to the HLR (that may result in an MSRN returned) it will need some way to differentiate that the SRI has originated from a Gateway node outside its own network. e.g. looking at

the SCCP Calling Party Number would show that the SRI was sent from an element outside the home infrastructure. However, if an IRN format number is used for the SRI SCCP CdPA from the Originating Mobile Network, then the DROF function may not need to look at the Calling Party Number to differentiate that the SRI had originated from a gateway not in its own network.

4.6 SMS delivery

In order to illustrate the most complex scenario conceivable, the call flow below assumes that SMS conveyance is in operation between the originating and donor networks. Currently SMS conveyance is not in place between UK mobile networks and therefore the originating and donor networks would be the same.

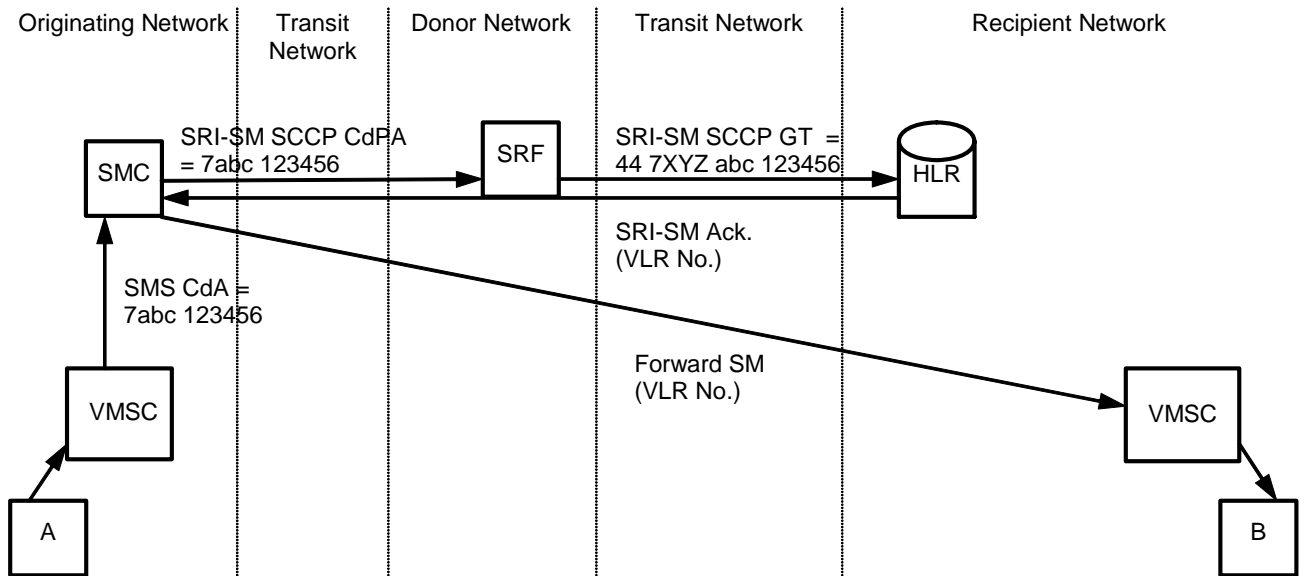

Figure 4.6 - SMS

4.7 SMS message waiting

In order to illustrate the most complex scenario conceivable, the call flow below assumes that SMS conveyance is in operation between the originating and donor networks. Currently SMS conveyance is not in place between UK mobile networks and therefore the originating and donor networks would be the same.

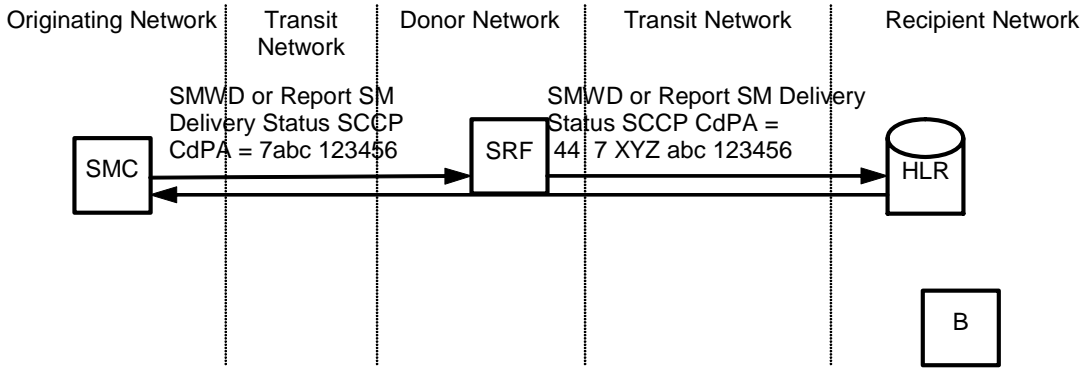

Figure 4.7 – SMS set message waiting

4.8 CCBS

The Activation, Suspension and Resume signals which are transferred from the originating side to the recipient network are relayed by the SRF. The Remote User Free signal, which is transferred in the opposite direction, is sent direct from recipient to originating networks using the C7 SCCP calling party address provided earlier. The final CCBS call is handled as another ported call.

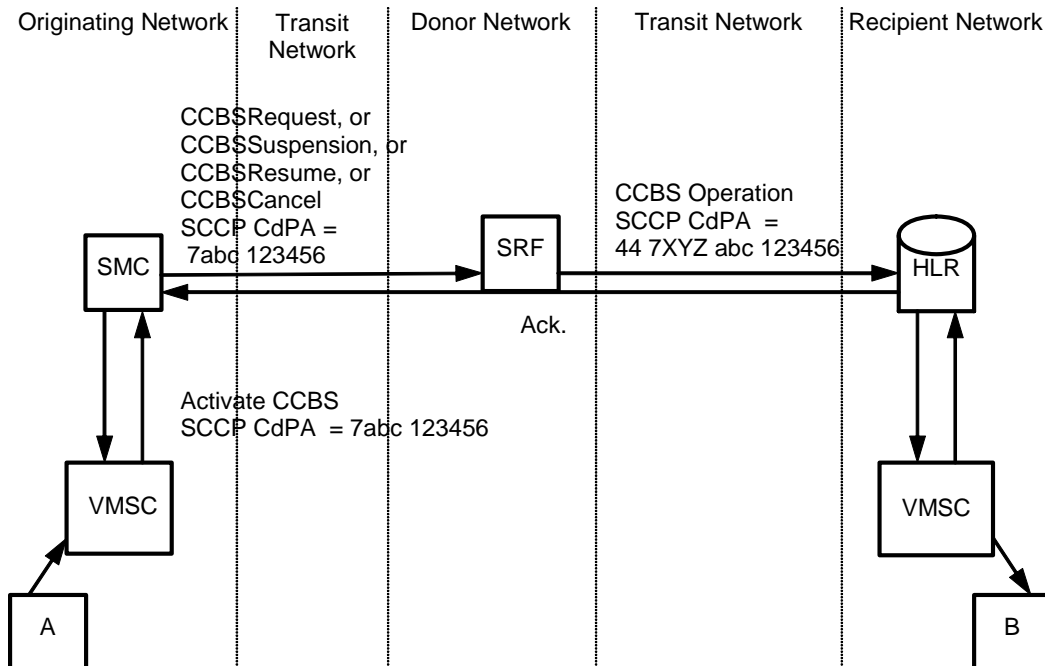

Figure 4.8 – Activation/Suspension/Resume/Cancel CCBS on ported subscriber

4.9 Send IMSI

In order to illustrate the most complex scenario conceivable, the originating network shown below is a VPLMN for the subscriber who has ported from donor to recipient networks. (ie. the ported subscriber has roamed onto a foreign network).

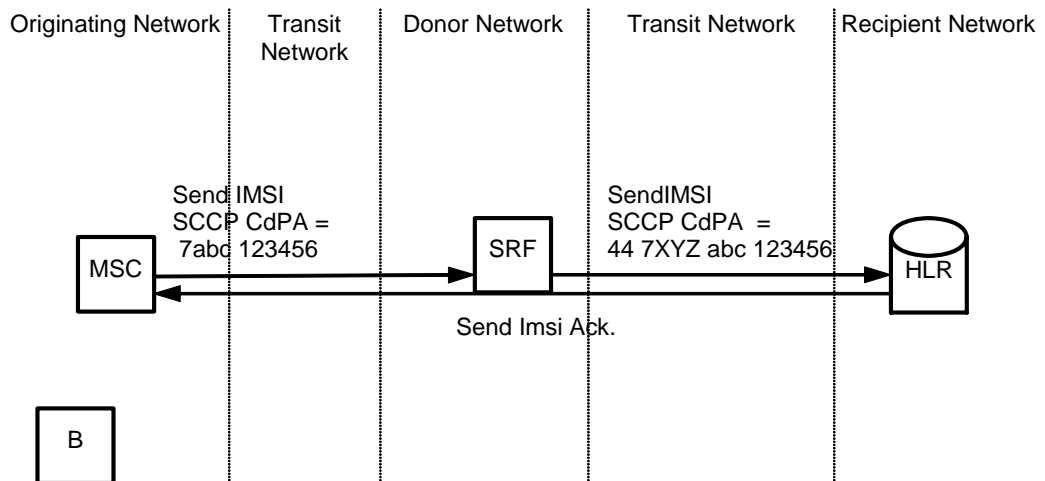

Figure 4.9 – SendImsi

5 SERVICE INTERACTIONS

In general, services based on circuit switched calls are under the control of the recipient network because calls to ported subscribers are routed to the recipient network.

5.1 Line identity presentation services

The ported number shall be stored in the location registers of the recipient network. In this way the ported number is provided as the line identity of the subscriber during mobile originated calls.

5.2 Emergency calls

When a mobile originated emergency call is made by a ported subscriber, the recipient network shall provide the emergency authorities with sufficient information to identify the serving network's identity.

5.3 CAMEL

The CAMEL Any Time Interrogation Request operation will be routed on MSISDN and is therefore applicable for relaying by the SRF in the Donor Network as described in Table 3.1 in Section 3.2.1.

5.4 Echo cancellers

Donor networks are not obliged to provide echo cancellers, but if they do they must support the normal echo canceller control protocols.

6 CALL TRAP

Call Trap is the ability of a recipient network to 'trap' calls to numbers which have been ported into the recipient network and which originated in the recipient network. This avoids routing of the call to the donor network and then back to the recipient (originating) network.

Call Trap can apply to both circuit-related calls and non-circuit related signalling (e.g. SMS messages, CCBS messages).

Call Trap is a matter entirely for the recipient network and its implementation, although beneficial is not mandatory.

7 ERROR HANDLING

7.1 MTP/SCCP/TC errors

With MNP in use MTP/SCCP/TC errors will be passed across UK interconnects. The handling of these errors is described in the relevant ITU-T and UK PNO-ISC specifications. There are no additional requirements for the handling of these errors placed on UK operators by MNP.

7.2 Unsuccessful call completion or application errors

As circuit switched calls to ported subscribers are routed to the recipient network, any announcements and tones generated as a result of call/service failure, call forwarding etc will be generated by the recipient network. No further action is needed for MNP.

• **APPENDIX A. ADDRESSING EXAMPLE FOR BASIC RELAY OPERATION**

- 1) Subscriber A dials B: 07abc 123456
- 2) The donor GMSC generates an SRI:
SRI MAP MSISDN = 7abc 123456
NAI = National
SCCP CdPA GT = B Pty - donor specific format
SCCP CgPA GT = GMSC (donor)
- 3) The SRF modifies the SCCP address:
SRI MAP MSISDN = 7abc 123456
NAI = National
SCCP CdPA GT = 447XYZ abc 123456
NAI=International
SCCP CgPA GT = GMSC (donor)
- 4) The recipient acknowledges:
SRI Ack MAP MSRN = 44 7nnn nnnnnn
NAI=International
SCCP CdPA GT = GMSC (donor)
SCCP CgPA GT = Recipient node address

Note: In stages 2), 3) and 4) if the call is ETSI optimally routed then the GMSC is an address in the originating network.

APPENDIX B. ADDRESSING EXAMPLE FOR DIRECT ROUTEING OVERRIDE OPERATION - RECIPIENT INITIATED

- 1) Subscriber A dials B: 07abc 123456
- 2) The donor GMSC generates an SRI:
SRI MAP MSISDN = 7abc 123456
NAI = National
SCCP CdPA GT = B Pty - donor specific format
SCCP CgPA GT = GMSC (donor)
- 3) The SRF modifies the SCCP address:
SRI MAP MSISDN = 7abc 123456
NAI = National
SCCP CdPA GT = 447XYZ abc 123456
NAI = International
SCCP CgPA GT = GMSC (donor)
- 4) The recipient acknowledges:
SRI Ack MAP MSRN = IRN
SCCP CdPA GT = GMSC (donor)
SCCP CgPA GT = Recipient node address
- 5) The donor routes the call
IFAM CdPA = IRN
- 6) The recipient generates an SRI:
SRI MSISDN = 7abc 123456
NAI = National
SCCP CdPA GT = 44 7abc 123456
NAI = International
SCCP CgPA GT = GMSC (recipient)

Note: In stages 2), 3) and 4) if the call is ETSI optimally routed then the GMSC is an address in the originating network.

End of TSG/SER/008